

8

7

6

5

4

3

2

1

REVISIONS				
REV.	ECN	DESCRIPTION	DATE	APPROVED
A	19-00407	INITIAL RELEASE	06/05/19	RCL

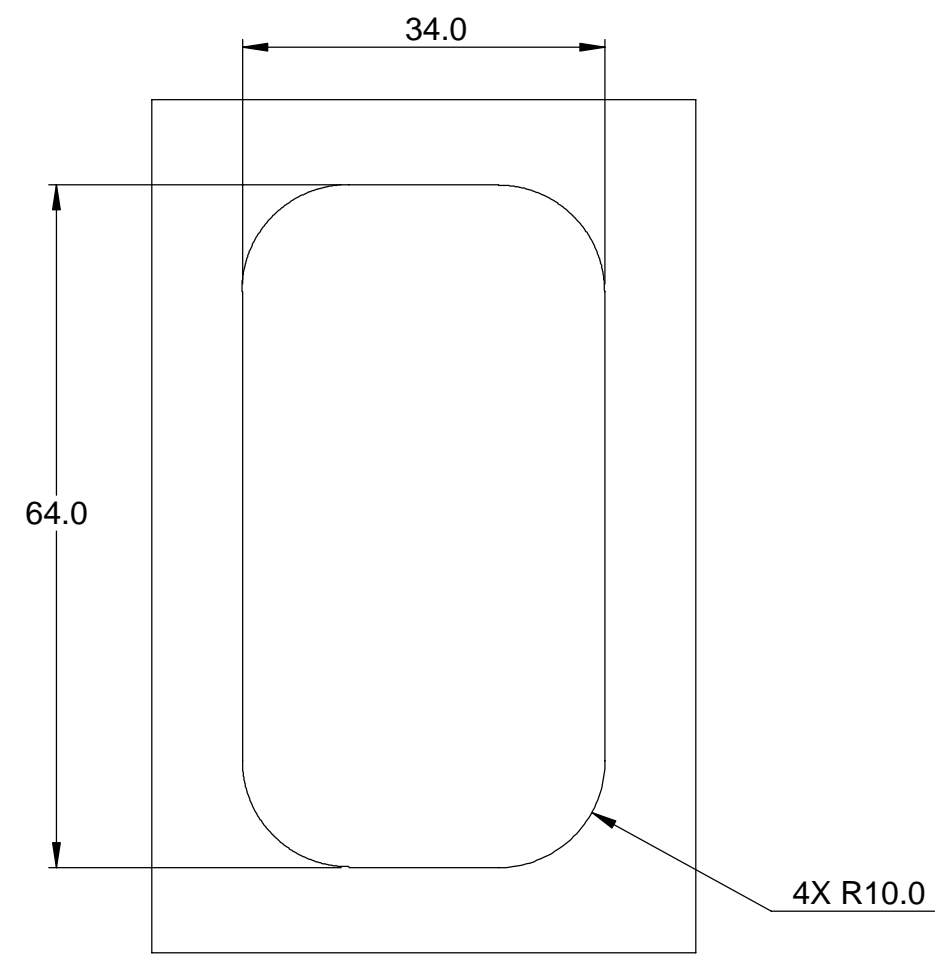
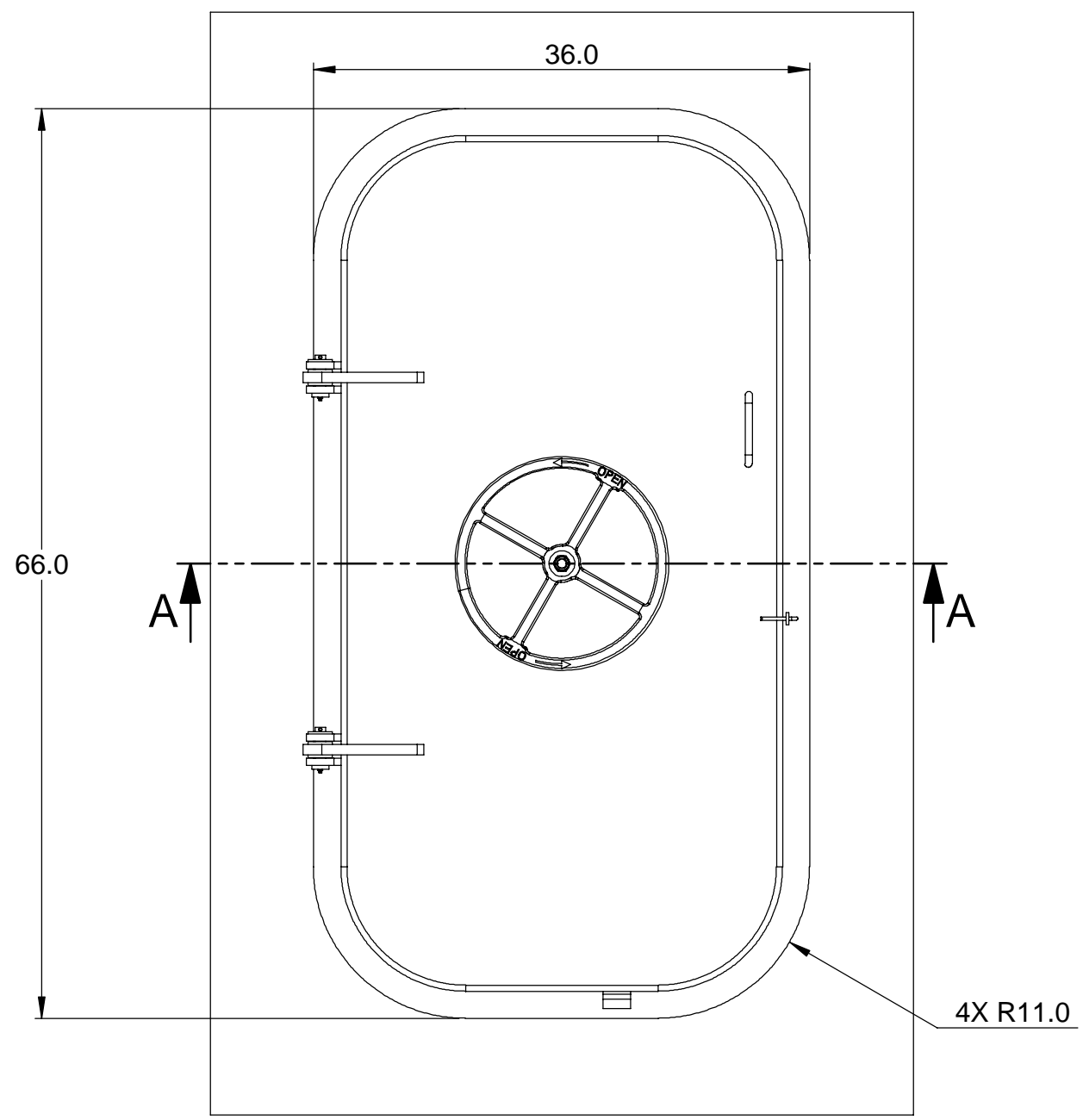

CUT-OUT DIMENSION VIEW
SCALE 1:18

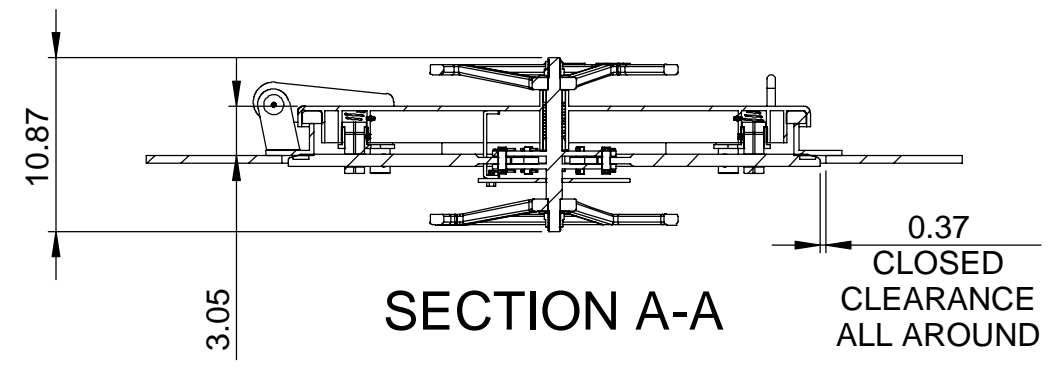

SECTION A-A

UMC P/N REF: 06122-101F

CLASS MAR	THE INFORMATION CONTAINED IN THIS DOCUMENT IS PROPRIETARY AND SHALL NOT BE PRODUCED OR USED FOR ANY PURPOSE WITHOUT THE WRITTEN APPROVAL OF UNIVERSAL MOTION COMPONENTS	INCHES	UMC UNIVERSAL MOTION COMPONENTS Co., INC. 2920 Airway Ave., Costa Mesa, CA 92626						
MATERIAL N/A									
WEIGHT(LBS) N/A									
THIRD ANGLE PROJECTION	<table border="1"> <tr> <td>DWN. BAE</td> <td>DT 06/04/19</td> </tr> <tr> <td>CK.</td> <td>DT</td> </tr> <tr> <td>APR.</td> <td>DT</td> </tr> </table>	DWN. BAE	DT 06/04/19	CK.	DT	APR.	DT	TOLERANCES: ANGLE $\pm 1/2^\circ$.X $\pm .06$.XX $\pm .03$.XXX $\pm .015$.XXXX $\pm .0050$	TITLE: DOOR ASSY, QUICK ACTING, 30" X 60", L/H
DWN. BAE	DT 06/04/19								
CK.	DT								
APR.	DT								
	SIZE B	DWG. NO. UMC-WTD-QA-30X60-L	REV. A						
SCALE: 1:12 AND NOTED		SHEET 1 OF 2							

8

7

6

5

4

3

2

1

8

7

6

5

4

3

2

1

D

D

C

C

B

B

A

A

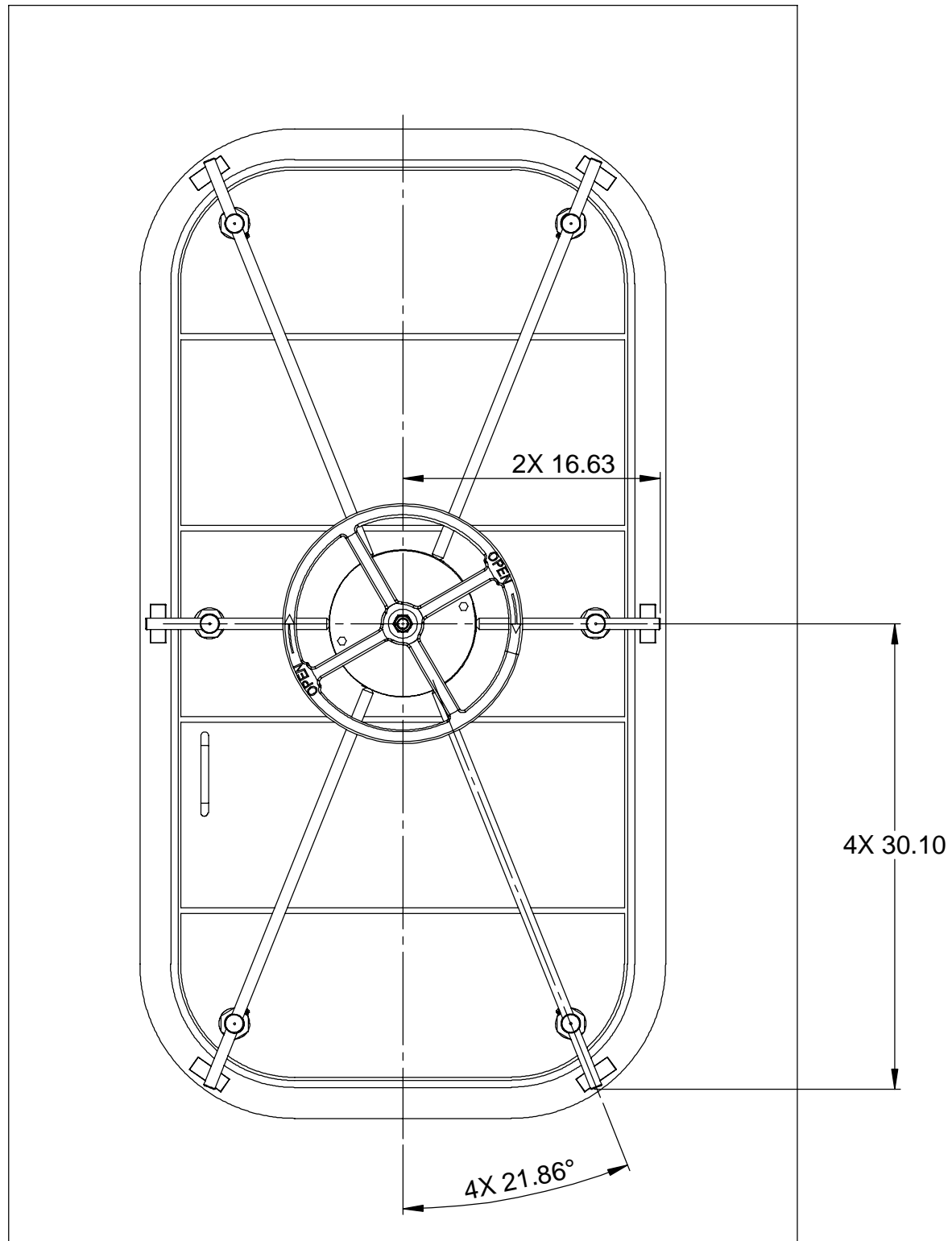

THIRD ANGLE PROJECTION

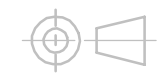

A

UMC P/N REF: 06122-101F

UMC UNIVERSAL MOTION
COMPONENTS Co., INC.
2920 Airway Ave., Costa Mesa, CA 92626

SIZE	DWG. NO.	REV.
B	UMC-WTD-QA-30X60-L	A
SCALE: 1:10 AND NOTED		SHEET 2 OF 2

8

7

6

5

4

3

2

1